

DUAL-WAVE SENSOR

ML SERIES



FEATURES & BENEFITS

- Affordable real-time organics monitoring solution
- Dual wavelength sensor (254 nm and 550 nm)
- Wastewater to high purity measurement ranges
- Operator friendly, low maintenance design
- Quick and simple optical measurements
- Reagent free operation
- Multiple parameter configuration available
- Parameters include TOC, DOC, UV254, UVT, TSS, colour

MUNICIPAL DRINKING WATER
MUNICIPAL WASTEWATER
INDUSTRIAL PROCESS WATER
INDUSTRIAL WASTEWATER

WATER QUALITY
MONITORING
SOLUTIONS

REAL-TIME MONITORING SOLUTION

ML Series Dual-Wave Sensor

Real Tech's ML series bypass sensor provides affordable real-time measurement of organic matter in water or wastewater. Designed to meet the needs of many monitoring applications, the series offers multiple sensor path length selections for the desired measurement range.

Controllers and Accessories

Our innovative modular product platform allows a system to be configured around the ideal sensor with controller options and various accessory products, including automatic chemical cleaning systems that lower maintenance while improving system performance and dilution systems that extend the measurement range for highly concentrated wastewaters. We can truly meet the physical demands of any installation, wastewater or high purity, to ensure reliable, continuous operation.

Real-time Actionable Data

With the right sensor and hardware configuration, we then build a custom calibration to monitor the aggregate organics parameter(s) or compounds of interest in real-time, accurately and reliably.

MEASUREMENT PRINCIPLE

The ML sensor utilizes light at 254 and 550 nm wavelengths. Many organic compounds, specifically aromatic organics, absorb light at 254 nm while interfering compounds are compensated for at 550 nm. Benefiting from Real Tech's innovative Ortho-Beam and Split-Sense Pro technologies, lamp drift and fluctuations are compensated for, providing an accurate and stable output overtime. ML series sensor parameters include TOC, DOC, UV254, UVT, TSS and colour.

REALTECH
INC.



DUAL-WAVE SENSOR

ML SERIES

SPECIFICATIONS

CHARACTERISTIC	TECHNICAL DATA									
	MODEL	ML2010	ML2020	ML2040	ML2100	ML3000	ML4050	ML4100	ML4150	ML4250
Path Length	1 mm	2 mm	4 mm	10 mm	10 mm x 20 mm	50 mm	100 mm	150 mm	250 mm	
Technology		Split-Sense Pro			Ortho -Beam			Split-Sense Pro		
Parameters		TOC, DOC, UV254, UVT, TSS colour								
Range		Depends on model selected. Refer to range chart on next page.								
Units		Parameter specific (mg/L, cm ⁻¹ , % or PCU)								
Sampling Time		10 seconds								
Calibration		Zero to DI water. Factory parameter calibration allows field adjustment as required.								
Cleaning		In-situ chemical cleaning makes cleaning quick and easy. Automatic chemical cleaning is optional.								
Self-Diagnostics		Detection and diagnosis of internal system fault								
Alarms		Dry contact terminals allow for operator configurable alarms for: high and low set points, low lamp output, leak detected, system fault, etc.								
Humidity Control		Humidity sensor with large plug-in regenerating desiccant system								
Wavelength		253.7 nm and 550 nm								
Light Source		Low-pressure mercury UV lamp and LED								
Lamp Life		2 years (mercury UV lamp)								
Enclosure		NEMA 4, wall mountable								
Flow Rate		300-1000 mL/min								
Pressure Rating		20 PSI								
Fluid Connections		1/4" OD tube push-in fittings								
Electrical/Comm.		From controller								
Storage Temp.		-20 to 60°C (-4 to 140°F)								
Operating Temp.		0 to 45°C (32 to 113°F)								
Weight		22 lb				24 lb				
Dimensions		17"H x 14.25"W x 7.5"D				17.75"H x 15.5"W x 6.75"D				
Warranty		2-year limited warranty (Extended care packages available)								
Sensor Upgrades		High Temp. Upgrade I, High Temp. Upgrade II								

*Technical Specifications are subject to change without notice.

DIMENSIONS

ML series sensors are bypass cabinet instruments installed directly on a wall, railing or system backboard. Sample is supplied to the sensor from either a pressurized source or from an open-channel using an accessory pumping system.

DIMENSIONS FOR ML2000 SERIES AND ML3000 MODELS

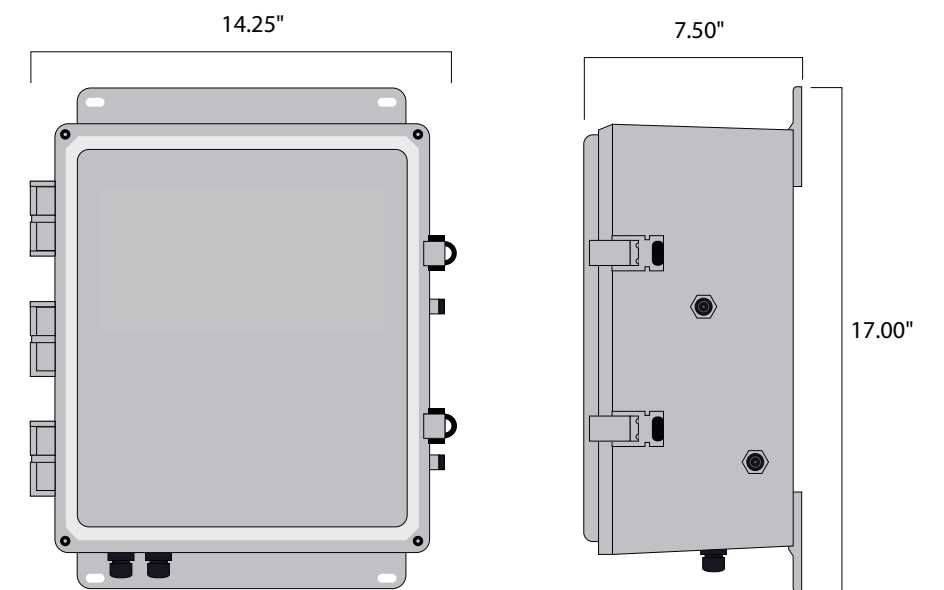

DIMENSIONS FOR ML4000 SERIES MODELS

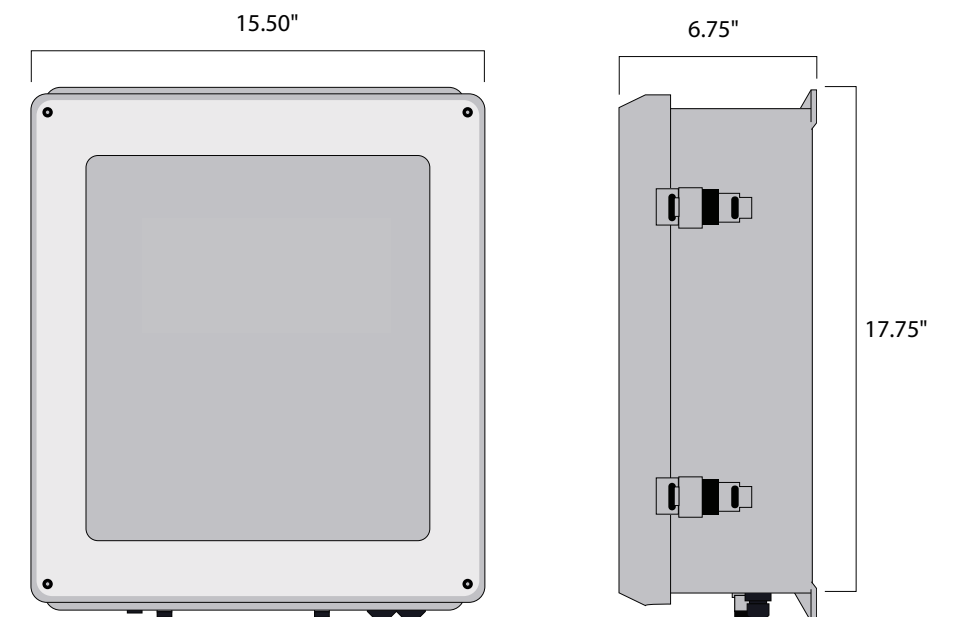

MODELS & RANGE

ML series models include dual-wave sensor, flow cell, calibration bottle and dehumidifier. Controller and accessories sold separately.

MODEL#	PATH LENGTH	UV254 (cm ⁻¹)	UVT (%)	TOC (mg/L)	DOC (mg/L)	COLOUR (PCU)
ML2010	1 mm	0 - 20	0 - 100	0 - 1200	0 - 800	0 - 6000
ML2020	2 mm	0 - 10	0 - 100	0 - 600	0 - 400	0 - 3000
ML2040	4 mm	0 - 5	0 - 100	0 - 300	0 - 200	0 - 1500
ML2100	10 mm	0 - 2	1 - 100	0 - 120	0 - 80	0 - 600
ML3000	10 x 20 mm	0 - 1	10 - 100	0 - 60	0 - 40	0 - 300
ML4050	50 mm	0 - 0.4	40 - 100	0 - 24	0 - 16	0 - 120
ML4100	100 mm	0 - 0.2	63 - 100	0 - 12	0 - 8	0 - 60
ML4150	150 mm	0 - 0.13	74 - 100	0 - 8	0 - 5.3	0 - 40
ML4250	250 mm	0 - 0.08	83 - 100	0 - 4.8	0 - 3.2	0 - 24

* Stated ranges are approximate, dependent on industry, site and application - contact Real Tech to confirm model selection

* Range for TSS is site specific, contact Real Tech for details

* Approximation of colour measurement based on UV254

* Higher maximum range possible with use of Dilution System option

CONTROLLERS

PRODUCT #	NAME	DESCRIPTION
S-169000	Real Controller	Wall mounted controller with 4-line x 20-character back lit LCD display for sensors
S-11TPC	Real Controller Pro	Wall mounted controller with touch panel PC interface (PC inside cabinet model)
S-11TPCD	Real Controller Pro	Wall mounted controller with touch panel PC interface (PC external on door model)

ACCESSORIES

PRODUCT #	NAME	DESCRIPTION
UVT-078130	Real Clean System I	Automatic chemical cleaning system for use with 2000 and 3000 series models
UVT-118010	Real Clean System II	Automatic chemical cleaning system for use with 4000 series models
UVT-079121	Pump Clean System I	Self-priming pump and automatic chemical cleaning for use with 2000 and 3000 series models
UVT-129122	Pump Clean System II	Self-priming pump and automatic chemical cleaning for use with 4000 series models
S-159124	Air Purge Clean System I	Automatic chemical cleaning, air purge and pump (vertical lift less than 8 ft and pumping distance less than 25ft)
S-179125	Air Purge Clean System II	Automatic chemical cleaning, air purge and booster pump (vertical lift exceeds 8ft or pumping distance exceeds 25 ft)
S-179126	Air Purge Clean System III	Automatic chemical cleaning and air purge. Client supplies pump or water is pressurized
S-169092	Dilution System I	Dilution system, automatic chemical cleaning, air purge and pump (vertical lift less than 8 ft and pumping distance less than 25ft)
S-179093	Dilution System II	Dilution system, automatic chemical cleaning, air purge and booster pump (vertical lift exceeds 8ft or pumping distance exceeds 25 ft)
S-179094	Dilution System III	Dilution system, automatic chemical cleaning and air purge. Client supplies pump or water is pressurized
S-1789121	Dual Feed II	Dual feed option includes Digital I/O module for use with controllers

Real Tech Inc.

1150 Champlain Court,
Whitby, Ontario L1N 6K9 Canada
TF: 1.877.779.2888 T: 1.905.665.6888
info@realtechwater.com

REALTECH
INC.