

# SPECTRUM SENSOR

## PL SERIES



### FEATURES & BENEFITS

- Highly accurate real-time water quality information
- Data rich, full scanning UV-VIS sensor (190-750 nm)
- Wastewater to high purity measurement ranges
- Simple optical measurements, no reagents
- Multiple parameter configuration available
- Parameters include BOD, COD, TOC, DOC, UV254, UVT, TSS, nitrate, nitrite, nitrite & nitrate, algae, permanganate, monochloramine, chromium VI, colour, dyes, pesticides, polymers, oil in water, diesel fuel, BTEX, surfactants, soaps, black liquor, H<sub>2</sub>S, O<sub>3</sub>, THM, HAA, ontaminant alarms, spectral fingerprint, custom alarm

MUNICIPAL DRINKING WATER  
MUNICIPAL WASTEWATER  
INDUSTRIAL PROCESS WATER  
INDUSTRIAL WASTEWATER

WATER QUALITY  
MONITORING  
SOLUTIONS

### REAL-TIME MONITORING SOLUTION

#### PL Series Spectrum Sensor

Real Tech's data-rich PL series bypass sensor provides real-time measurement of a wide array of parameters and compounds in water or wastewater. Designed to meet the needs of many monitoring applications, the series offers multiple sensor path length selections for the desired measurement range.

#### Controllers and Accessories

Our innovative modular product platform allows a system to be configured around the ideal sensor with controller options and various accessory products, including automatic chemical cleaning systems that lower maintenance while improving system performance and dilution systems that extend the measurement range for highly concentrated wastewaters. We can truly meet the physical demands of any installation, wastewater or high purity, to ensure reliable, continuous operation.

#### Liquid Ai Compatible

With the right sensor and hardware configuration, we then use custom data analysis and machine learning algorithms to bring true meaning to the data. This technique ensures accuracy and reliability so our clients can have the utmost confidence in their results. The longer our systems are installed, the smarter they become as they continue to learn the characteristics of the site-specific water with our Liquid Ai services.

### MEASUREMENT PRINCIPLE

The PL sensor utilizes UV-VIS light between 190-750 nm for measurement, continuously scanning the water every minute of every day collecting hundreds of data points. The sensor benefits from Real Tech's innovative Split-Sense Pro technology that compensates for lamp drift and fluctuations, providing an accurate and stable output overtime. PL series sensor parameters include BOD, COD, TOC, DOC, UV254, UVT, TSS, nitrate, nitrite, nitrite & nitrate, algae, permanganate, monochloramine, chromium VI, colour, dyes, pesticides, polymers, oil in water, diesel fuel, BTEX, surfactants, soaps, black liquor, H<sub>2</sub>S, O<sub>3</sub>, THM, HAA, ontaminant alarms, spectral fingerprint, custom alarm and more, dependant on application and industry.

**REALTECH**  
INC.



# SPECTRUM SENSOR **PL** SERIES SPECIFICATIONS

## CHARACTERISTIC

## TECHNICAL DATA

MODEL	PL2010	PL2020	PL2040	PL2080	PL4025	PL4050
Path Length	1 mm	2 mm	4 mm	8 mm	25 mm	50 mm
Parameters	BOD, COD, TOC, DOC, UV254, UVT, TSS, nitrate, nitrite, nitrite & nitrate, algae, permanganate, monochloramine, chromium VI, colour, dyes, pesticides, polymers, oil in water, diesel fuel, BTEX, surfactants, soaps, black liquor, H <sub>2</sub> S, O <sub>3</sub> , THM, HAA, contaminant alarms, spectral fingerprint, custom alarm					
Range	Depends on model selected. Refer to range chart on next page.					
Units	Parameter specific (mg/L, cm <sup>-1</sup> , % or PCU)					
Sampling Time	1 minute					
Calibration	Zero to DI water. Factory parameter calibration allows field adjustment as required.					
Cleaning	In-situ chemical cleaning makes cleaning quick and easy. Automatic chemical cleaning is optional.					
Self-Diagnostics	Detection and diagnosis of internal system fault					
Alarms	Dry contact terminals allow for operator configurable alarms for: high and low set points, low lamp output, leak detect, system fault, etc.					
Humidity Control	Humidity sensor with large plug-in regenerating desiccant system					
Wavelengths	Full scanning between 190-750 nm					
Light Source	Deuterium and Tungsten					
Lamp Life	4000 hrs. each					
Dimensions	19.0"H x 20.5"W x 9.0"D					
Enclosure	NEMA 4, wall mountable					
Flow Rate	300-1000 mL/min					
Pressure Rating	20 PSI					
Fluid Connections	1/4" tube push-in fittings					
Electrical/Comm.	From controller					
Storage Temp.	-20 to 60°C (-4 to 140°F)					
Operating Temp.	0 to 45°C (32 to 113°F)					
Weight	44 lb					
Technology	Split-Sense Pro					
Warranty	2-year limited warranty (Extended care packages available)					
Sensor Upgrades	Cooling Upgrade I, Cooling Upgrade II, Ultra High Temp./Chemical Upgrade, Seawater Upgrade					

## DIMENSIONS

PL sensor is a bypass cabinet instruments installed directly on a wall, railing or system backboard. Sample is supplied to the sensor from either a pressurized source or from an open-channel using an accessory pumping system.

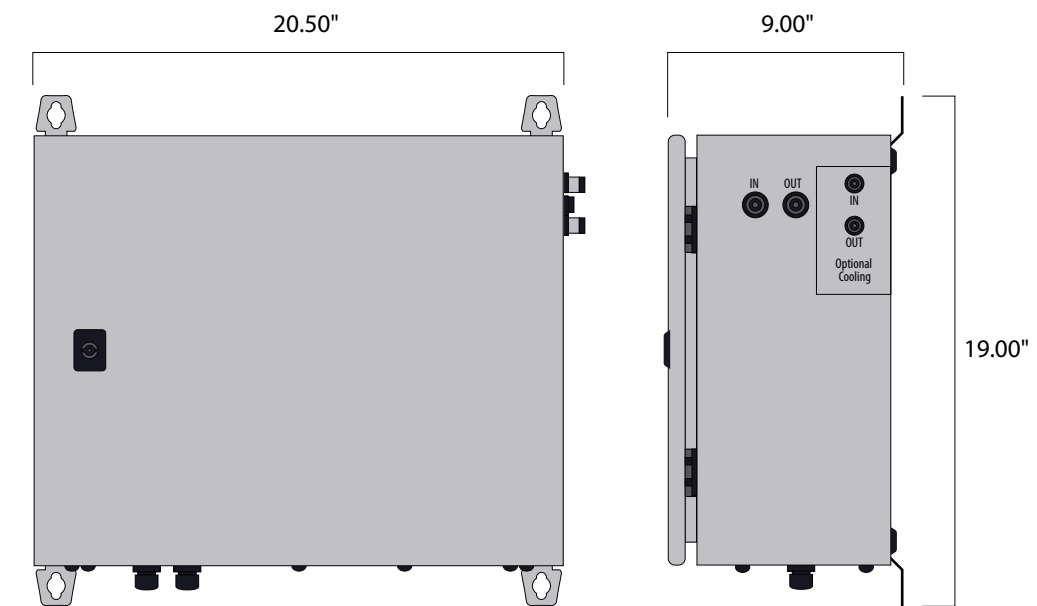

## MODELS & RANGE

PL series models include UV-VIS sensor, flow cell, calibration bottle and dehumidifier. Controller and accessories sold separately.

MODEL #	PATH LENGTH	BOD (mg/L)	COD (mg/L)	TOC (mg/L)	DOC (mg/L)	UV254 (cm <sup>-1</sup> )	COLOUR (PCU)	NO <sub>3</sub> -N (mg/L)	NO <sub>3</sub> (mg/L)	NO <sub>2</sub> -N (mg/L)
PL2010	1 mm	0 - 1500	0 - 3000	0 - 1200	0 - 800	0 - 20	0 - 6000	0 - 50	0 - 220	0 - 50
PL2020	2 mm	0 - 750	0 - 1500	0 - 600	0 - 400	0 - 10	0 - 3000	0 - 25	0 - 110	0 - 25
PL2040	4 mm	0 - 375	0 - 750	0 - 300	0 - 200	0 - 5	0 - 1500	0 - 12.5	0 - 55	0 - 12.5
PL2080	8 mm	0 - 187	0 - 375	0 - 150	0 - 100	0 - 2.5	0 - 750	0 - 6.25	0 - 27.5	0 - 6.25
PL4025	25 mm	0 - 60	0 - 120	0 - 48	0 - 32	0 - 0.8	0 - 240	0 - 2	0 - 8.8	0 - 2
PL4050	50 mm	0 - 30	0 - 60	0 - 24	0 - 16	0 - 0.4	0 - 120	0 - 1	0 - 4.4	0 - 1

\* Stated ranges are approximate, dependent on industry, site and application - contact Real Tech to confirm model selection

\* Range for algae, permanganate, chromium, dyes, pesticides, oil in water, diesel fuel, BTEX, black liquor, soaps, surfactants, H<sub>2</sub>S, O<sub>3</sub>, THM, HAA, contaminant alarms, spectral fingerprint, custom alarm are site specific, contact Real Tech for details

\* Higher maximum range possible with use of Dilution System option

## CONTROLLERS

PRODUCT #	NAME	DESCRIPTION
S-11TPC	Real Controller Pro	Wall mounted controller with touch panel PC interface (PC inside cabinet model)
S-11TPCD	Real Controller Pro	Wall mounted controller with touch panel PC interface (PC external on door model)

## ACCESSORIES

PRODUCT #	NAME	DESCRIPTION
UVT-078130	Real Clean System I	Automatic chemical cleaning system for use with 2000 and 3000 series models
UVT-118010	Real Clean System II	Automatic chemical cleaning system for use with 4000 series models
UVT-079121	Pump Clean System I	Self-priming pump and automatic chemical cleaning for use with 2000 and 3000 series models
UVT-129122	Pump Clean System II	Self-priming pump and automatic chemical cleaning for use with 4000 series models
S-159124	Air Purge Clean System I	Automatic chemical cleaning, air purge and pump (vertical lift less than 8 ft and pumping distance less than 25ft)
S-179125	Air Purge Clean System II	Automatic chemical cleaning, air purge and booster pump (vertical lift exceeds 8ft or pumping distance exceeds 25 ft)
S-179126	Air Purge Clean System III	Automatic chemical cleaning and air purge. Client supplies pump or water is pressurized
S-169092	Dilution System I	Dilution system, automatic chemical cleaning, air purge and pump (vertical lift less than 8 ft and pumping distance less than 25ft)
S-179093	Dilution System II	Dilution system, automatic chemical cleaning, air purge and booster pump (vertical lift exceeds 8ft or pumping distance exceeds 25 ft)
S-179094	Dilution System III	Dilution system, automatic chemical cleaning and air purge. Client supplies pump or water is pressurized
S-1789121	Dual Feed II	Dual feed option includes Digital I/O module for use with controllers

### Real Tech Inc.

1150 Champlain Court,  
Whitby, Ontario L1N 6K9 Canada  
TF: 1.877.779.2888 T: 1.905.665.6888  
info@realtechwater.com

